

Your best choice for
better posture

curble

POSTURE CORRECTOR CHAIR



What is your problem every time you sit down?



BACK PAIN



A BENT POSTURE



TURTLE NECK SYNDROME

Disc Care System considering multiple uses

Curble Chair is designed for office workers and students who spend most of the time sitting on a chair to keep a good posture even on a couch or a bed and have a healthy spine line.

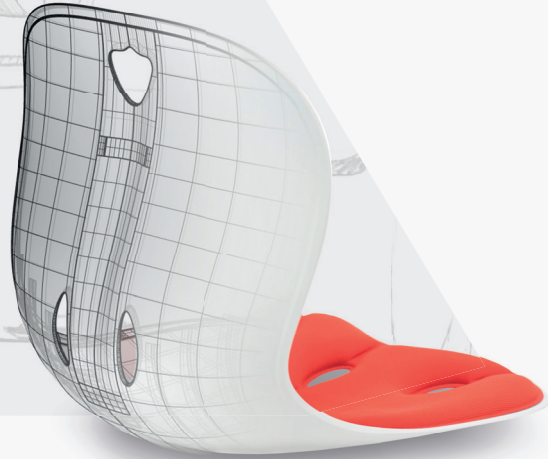

curble
chair **Comfy**

Color



Gray



Blue



Red



Black



Sitting



Coccyx lifted



Supporting waist

3 Supporting waist

2 Coccyx lifted

1 Sitting



Professional mechanism with the leverage effect.

The highly elastic support with the principle of the lever ensures correct posture for your spine and waist.

curble chair **Wider**

Color

Gray



Red



Black



Dispersion of Waist Pressure

Curble Chair naturally brings hips together to disperse the pressure concentrated on the waist to allow users to sit comfortably for longer.



Raising

Center muscle correction

Lifestyle with Curble



Curble chair Comfy

Dimension(cm)

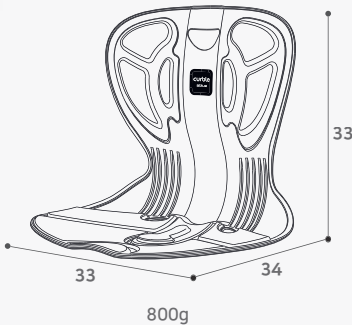

Curble chair Wider

Dimension(cm)

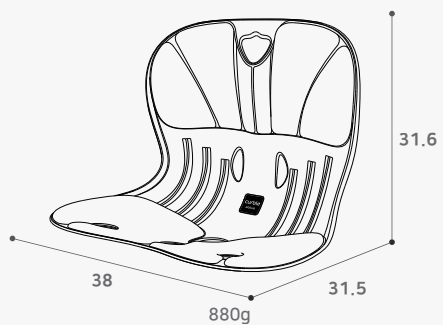

ablue | Emotional design laboratory

ablue bldg, 2F, 56, Bongseong-ro, Gunpo-si, Gyeonggi-do, 15850, Korea | Tel : +82(0)70-7700-0861 | e-mail : global@ablue.kr
www.ablue-global.com